

Functional Test Data

OUTPUT BIT	FUNCTION	INPUT BIT	FUNCTION
2	ALARM LED 1 = ON 0 = OFF	2	ALARM LED CONFIRMATION 1 = ON 0 = OFF
1	REMOTE TEST 1 = TEST ENABLED 0 = NORMAL	1	INDICATES WIRING CLASS 1 = CLASS B* 0 = CLASS A
0	NOT USED	0	ALARM STATUS 1 = ALARM 0 = NORMAL

* Note: Toggles to '0' in alarm.

Technical Data

	Specifications
Nominal Operating Voltage	16-28 VDC
Maximum Wiring Loop Resistance	40Ω
Temperature Range	32° F to 120° F (0° C to 49° C)
Humidity	0% to 95% (No condensation or icing)
Dimensions	3.0" W x 2.0" H x 0.75" D

Monitored circuit**Current consumption**

Quiescent	600μA
Alarm (LED on)	4.6mA
End-of-line supervisory resistance	47kΩ, 0.5W

Analog levels

Open-circuit fault	4
Normal	16
Alarm on switch closure	64

Compatibility Information

The Mini Priority Monitor module has been approved by Underwriters Laboratories Inc. For details of compatible control panels, please contact Summit directly.

Summit Systems Technologies

Canada
25 Interchange Way, Vaughan, Ontario, L4K 5W3
Tel: (905) 695-3549, Fax: (905) 660-4113

USA
4575 Witmer Industrial Estates, Niagara Falls, New York 14305
Tel Toll Free: 1-866-SUMMIT-0, Fax Toll Free: (888) 660-4113

Website: www.summit-st.net



Mini Priority Monitor Module Installation Instructions

General

The Mini Priority Monitor Module, part no SIM-101P, is a loop-powered device, which incorporates a monitored input circuit for connection to switches. The module is supplied as a small plastic housing designed to fit into an electrical box. Six flying leads of 18AWG are used to connect the module. It also has a priority interrupt facility to give fast response and can be fitted in an electrical box behind the pull station.

A red LED flashes in synchronization with the current pulse reply from the device. If output bit 2 is set the LED is illuminated continuously.

The Mini Priority Monitor Module, part no SIM-101P, has a priority interrupt facility to give fast response and can be fitted in an electrical box behind a pull station.

Note: the Mini Priority Monitor Module is not designed for outdoor use unless it is mounted in a suitable weatherproof enclosure.

Installation

1. The Mini Priority Monitor Module is not physically attached to the electrical box other than by means of the flying leads.
2. Connect the modules for Class A wiring or Class B wiring (Fig 2). Bit 8 of the DIL switch is used to select the class of wiring. All wiring must conform to local codes and regulations.

Note: all circuits are power limited. Use only limited energy cable types FPL, FPLR or FPLP on power limited circuits.

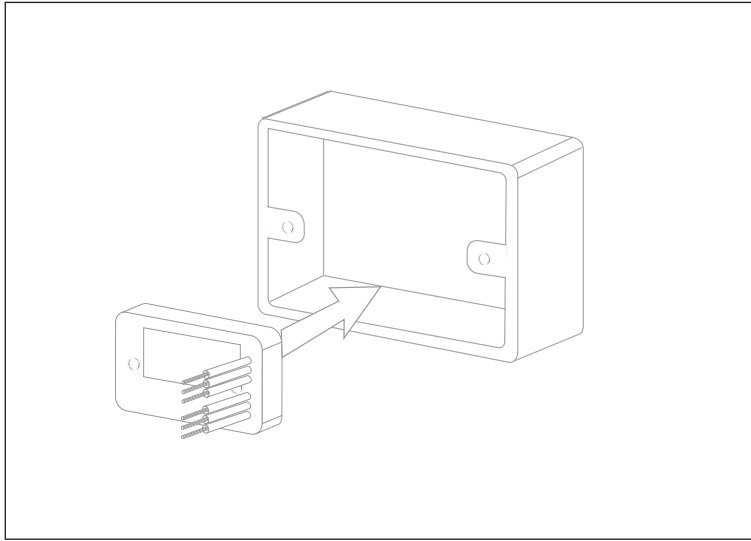

Fig 1. Mounting the module

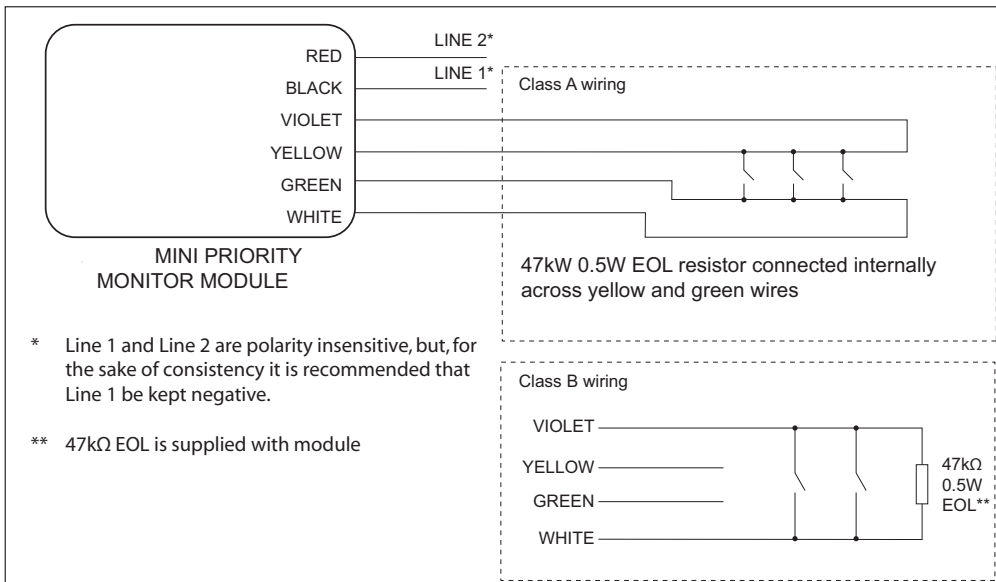

Fig 2. Wiring Diagram for Mini Priority Monitor Module

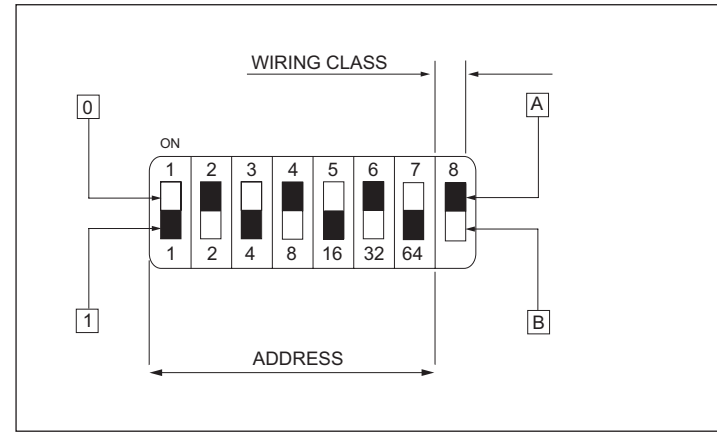

Fig 3. DIL Switch

Address Setting

Segments 1-7 of the DIL switch are used to select the address of the module. Each of the seven segments must be set to '0' (ON) or '1' (OFF) using a small screwdriver or similar tool. A complete list of address settings is shown below. (The eighth segment of the switch is used to select Class A or B wiring).

addr	DIL switch setting 1234567	addr	DIL switch setting 1234567	addr	DIL switch setting 1234567	addr	DIL switch setting 1234567	addr	DIL switch setting 1234567
1	1000000	11	1101000	21	1010100	31	1111100	41	1001010
2	0100000	12	0011000	22	0110100	32	0000010	42	0101010
3	1100000	13	1011000	23	1110100	33	1000010	43	1101010
4	0010000	14	0111000	24	0001100	34	0100010	44	0011010
5	1010000	15	1111000	25	1001100	35	1100010	45	1011010
6	0110000	16	0000100	26	0101100	36	0010010	46	0111010
7	1110000	17	1000100	27	1101100	37	1010010	47	1111010
8	0001000	18	0100100	28	0011100	38	0110010	48	0000110
9	1001000	19	1100100	29	1011100	39	1110010	49	1000110
10	0101000	20	0010100	30	0111100	40	0001010	50	0100110
51	1100110	61	1011110	71	1110001	81	1000101	91	1101101
52	0010110	62	0111110	72	0001001	82	0100101	92	0011101
53	1010110	63	1111110	73	1001001	83	1100101	93	1011101
54	0110110	64	0000001	74	0101001	84	0010101	94	0111101
55	1110110	65	1000001	75	1101001	85	1010101	95	1111101
56	0001110	66	0100001	76	0011001	86	0110101	96	0000011
57	1001110	67	1100001	77	1011001	87	1110101	97	1000011
58	0101110	68	0010001	78	0111001	88	0001101	98	0100011
59	1101110	69	1010001	79	1111001	89	1001101	99	1100011
60	0011110	70	0110001	80	0000101	90	0101101	100	0010011
101	1010011	111	1111011	121	1001111				
102	0110011	112	0000111	122	0101111				
103	1110011	113	1000111	123	1101111				
104	0001011	114	0100111	124	0011111				
105	1001011	115	1100111	125	1011111				
106	0101011	116	0010111	126	0111111				
107	1101011	117	1010111						
108	0011011	118	0110111						
109	1011011	119	1110111						
110	0111011	120	0001111						