

## Mircom FHS-240 Select-A-Horn/Strobe Series



### Description

Mircom's Select-A-Strobe/Horn Series is designed to comply with the Americans with Disability Act (ADA) and meet UL standard 1971 requirements for emergency signaling devices for the hearing impaired.

The Select-A-Strobe/Horn FHS-240 series features a unique candela intensity field selector switch for alternating the candela output 15cd to 30cd (75cd on axis). The Horn provides two different field selectable tones, and a High/Low output setting that can be achieved with the use of mini jumpers located on back of the unit.

These appliances are polarized for connecting to supervised fire alarm circuits. The strobe is designed with a xenon flashtube and provides a candela intensity field selector switch for maximum performance.

The FHS-240 can be synchronized by using the SDM-204 Sync Module to comply with NFPA recommendations concerning photosensitive epilepsy when installing 2 or more visual appliances within the field of view. The strobe signals are listed for indoor use, wall mount, under UL 1971 standard.

### Engineering Specifications

The audible and visual alarm indicating appliance shall be a model FHS-240 or equivalent device. The Strobe shall be listed under UL 1971 Standard for signaling devices for the hearing impaired and shall be approved for fire protective service. The candela output shall be field selectable, having a dual setting of 15cd or 30cd output.

### Features

- Meets or exceeds NFPA/ANSI Standards and ADA Accessibility Guidelines
- UL listed for wall mounting
- Screw terminal capacity up to 12 AWG
- Universal mounting plate included
- 24V DC strobe with two field selectable settings: 15cd, 30cd
- Polarized strobes with wide operating voltage range using filtered DC or unfiltered FWR input voltage
- Horn field selectable tones
  - 3000 Hz interrupted or Electro-mechanical
  - Temporal or Non-temporal
  - High or Low dBA output
- Mounts to 4" square, single gang, double gang or octagonal back box
- Tamper-proof candela selector switch
- Synchronization requires Sync Module (SDM-240)
- Available in red or white housing

The Horn shall provide two different field selectable temporal or steady tones, and a High and Low field selectable sound output setting. The signaling Strobe shall operate on 24VDC from a non-coded regulated DC supply or full-wave rectified, unfiltered supply.

The Horn may operate on 24VDC coded system. The Strobe shall be designed to produce one signal flash per second with continuously applied minimum voltage. The Strobe/Horn shall have a universal back mounting plate, capable of WALL mounting to a back box.

When strobe synchronization is required, the Strobe/Horn shall be compatible with the SDM-240 (daisy chain) or other source of sync protocol. Audible and visual signaling devices shall be installed in accordance with current NFPA guideline.



## Dimensions

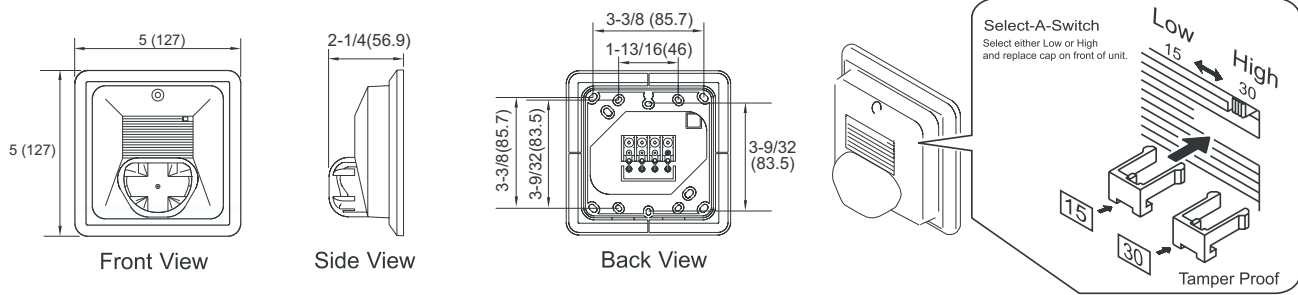

## UL Required Minimum Light Output (cd)

Degrees	Wall Mount Horizontal		Wall Mount Vertical	
	@ 15 cd	@ 30 cd	@ 15 cd	@ 30 cd
0	75.00	75.00	75.00	75.00
5 ~ 25	13.50	27.00	3.50	27.00
30	11.25	22.50	13.50	27.00
40	11.25	22.50	6.90	13.80
45	11.25	22.50	5.10	10.20
50	8.25	16.50	4.05	8.10
55	6.75	13.50	3.30	6.60
60	6.00	12.00	2.70	5.40
65	5.25	10.50	2.40	4.50
70	5.25	10.50	2.25	4.50
75	4.50	9.00	1.80	3.60
80	4.50	9.00	1.80	3.60
85 ~ 90	3.75	7.50	1.80	3.60
Compound 45	3.60	7.20	-	-

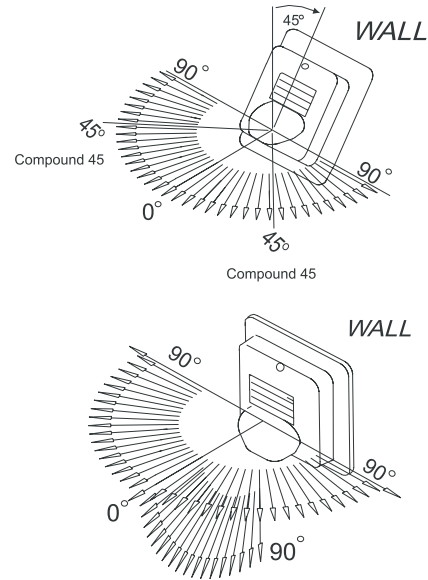

## Wiring Diagrams

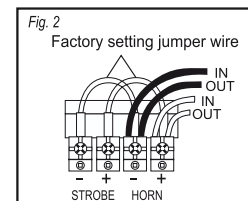
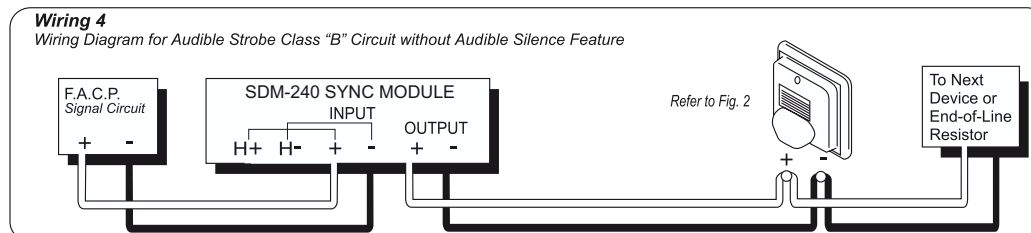
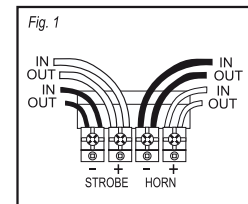
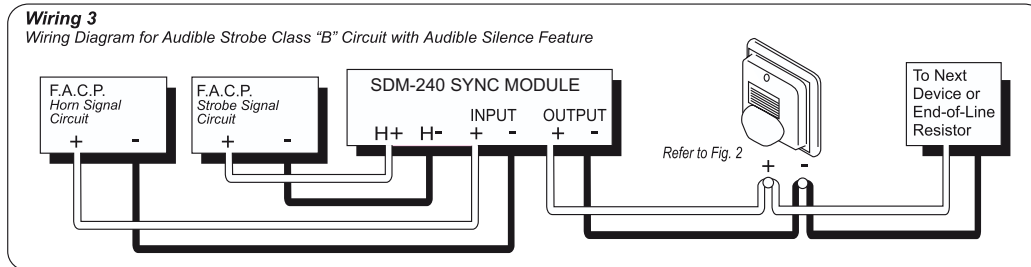
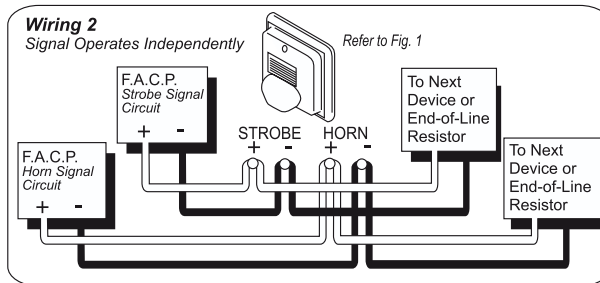
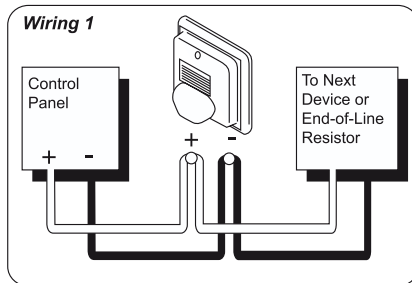

## Specifications

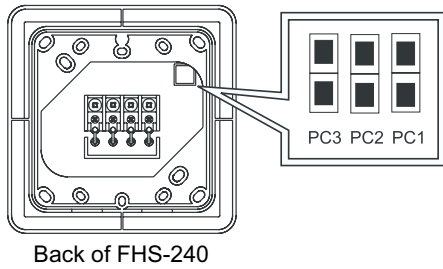

Jumper	PC3 Pattern	PC2 Tone	PC1 Volume
	Non-Temporal	Electro-Mechanical	High
	Temporal	3000 Hz	Low

## Installation Options

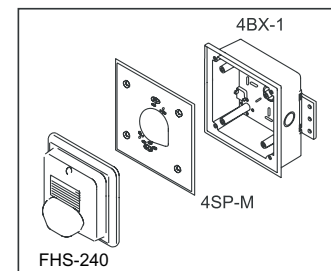
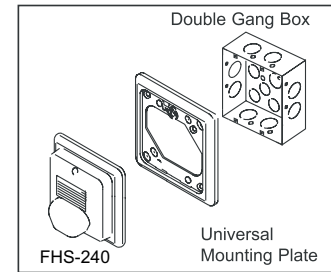
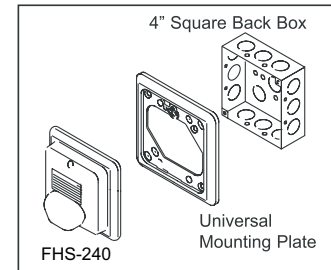
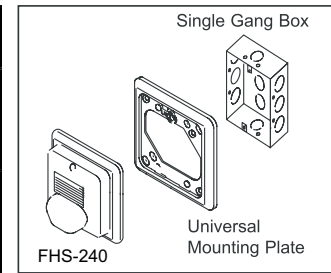

Strobe/Horn Current Draw Table				PC3: Pattern PC2: Tone PC1: Volume			Max. RMS Operating Current (mA)		Min. Sound Output (dBA @ 10ft per UL464)	
				PC3	PC2	PC1	Regulated 24V DC	Regulated 24V FWR	Regulated 24V DC	
Horn & Strobe (Low)	Non-Temp	Electro-Mechanical	High	1	1	1	112	145	83	
			Low	1	1	0	109	142	74	
		3000 Hz	High	1	0	1	118	153	84	
	Low		1	0	0	106	139	74		
	Horn & Strobe (High)	Non-Temp	Electro-Mechanical	High	1	1	1	158	207	83
				Low	1	1	0	155	204	74
3000 Hz			High	1	0	1	164	215	84	
		Low	1	0	0	152	201	74		
Horn Only		Non-Temp	Electro-Mechanical	High	1	1	1	57	91	83
				Low	1	1	0	42	44	74
	3000 Hz		High	1	0	1	70	68	84	
		Low	1	0	0	36	38	74		
	Horn Only	Non-Temp	Electro-Mechanical	High	0	1	1	57	91	79
				Low	0	1	0	42	44	69
3000 Hz			High	0	0	1	70	68	80	
		Low	0	0	0	36	38	70		

Strobe Light Only	Max. RMS Operating Current (mA)	
	Regulated 24V DC	Regulated 24V FWR
15cd	88	127
30cd	134	184

Under ULC 525/526	ULC Current @ 24VDC (mA)	
	Low Volume	High Volume
15cd	79	92
30cd	111	124

## Sound Output Dispersion

Degrees	Wall Mount Horizontal	Wall Mount Vertical
+90	-6 dB	-3 dB
+60	-2 dB	-2 dB
+30	-1 dB	-1 dB
0	0dB	0 dB
-30	-1 dB	-3 dB
-60	-2 dB	-5 dB
-90	-6 dB	-6 dB

## Warning

- Strobes must be used only on circuits with continuously operating voltage. DO NOT use strobe on coded or interrupted circuits in which the applied voltage is interrupted ON and OFF as the strobe may fail to flash.
- The applied voltage must be within its rated input voltage range.
- Fuse ratings on signaling circuits must handle peak currents from all devices connected to those circuits.

## SDM-240 Sync Module



### Description

The Sync Module is designed to provide a synchronized temporal pattern (code 3) tone, and synchronized the strobe flashes when used with the Select-A-Strobe/Horn series as well as the ability to silence the horn while maintaining the strobe flashes.

The SDM-240 has the capability of connecting two style Y (Class B) circuits or one style Z (Class A) circuit and is rated for 3 amperes per circuit.

The SDM-240 can be interconnected so that more than two alarm zones can be synchronized when connected using the SYNC terminals (daisy chain connection). The maximum number of interconnected modules is 20. All inputs are polarized for compatibility with standard reverse polarity supervision of circuit wiring, when used with FACP.

### Specifications

<b>Input Voltage</b>	Regulated 24V DC/FWR	
<b>Operating Voltage Range</b>	16 ~ 33V DC/FWR	
<b>Maximum Load on Loop</b>	3A Average Max. 5A Peak	
<b>Max. RMS Operating Current</b>	<b>DC</b>	34mA
	<b>FWR</b>	68mA
<b>Mounting Backbox</b>	4" x 4" x 1½"	
<b>Operating Temperature Range</b>	32°F ~ 120°F (0°C ~ 49°C)	

### Ordering Information

Model Number	Housing Color	Input Voltage	Operating Voltage Range	Selectable Strobe Output (cd)	Horn Sound Output	Wiring Type	Mounting Type	Sync Module	Temperature Operating Range
FHS-240R	Red	Regulated 24V DC/FWR	16 ~ 33VDC	15 or 30	Selectable	Terminals	Wall Mount	SDM-240	32°F ~ 120°F (0°C~49°C)
FHS-240W	White		16 ~ 33VFWR						

### Features

- Polarized with wide operating voltage range using filtered DC or unfiltered FWR input voltage
- Mounts onto 4-inch square back box
- Daisy chain up to 20 modules maximum
- Screw terminal capacity up to AWG#12
- Red metal plate

### Dimensions

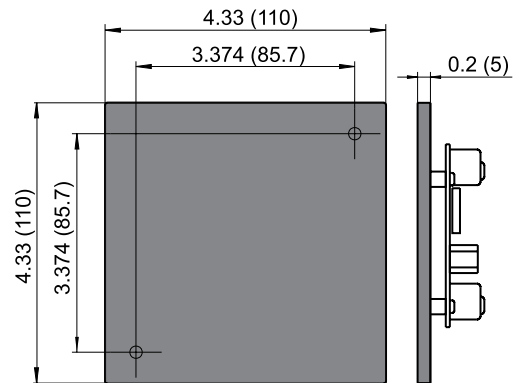

### Daisy Chain Modules

