

FIRERAY 50RU/100RU **Reflective Beam Smoke Detector**



Description

The system comprises of a single unit incorporating an infra-red transmitter and receiver. The signal generated in the transmitter element and reflected by the prism back to the receiver element is analyzed for the presence of smoke. The internal microprocessor determines an alarm condition when a predetermined level is reached. The system is designed to be mounted so the beam will project between 1ft. (0.305 m) and 2ft. (0.61m) below and parallel to the ceiling. Lateral detection may be up to 30ft. (9.144m) on either side of the beam, providing a maximum total coverage area of up to 19,800 square feet (60ft. x 330ft. or 18.288m x 100m).

Engineering Specifications

The projected beam type smoke detector shall be a 4-wire 12/24 VDC device to be used with an U.L. Listed separately supplied 4-wire control panel. Unit shall be listed to U.L. 268 and shall consist of an integrated transmitter and receiver. The detector shall operate between a range of 15 ft. to 330 ft. (5m to 100m). The temperature range of the beam shall be -22°F to 131°F (-30°C to +55°C). The beam detector shall feature automatic gain control which will compensate for gradual signal deterioration from dirt accumulation on the lenses. The unit shall include a wall mounting bracket. Testing shall be carried out by using a calibrated obscuration test filter. The Reflective beam type smoke detector shall be a Fire Fighting Enterprises 50RU (160 ft./50m) or 100RU (330 ft./100m).

Features

- 2 Models for ranges of:
 - 15 ft. to 160 ft. (5m to 50m)
 - 160 ft. to 330 ft. (50m to 100m)
- Easy set up and alignment
- Single Compact Housing
- Calibrated obscuration test filter included
- 3 selectable alarm thresholds:
 - 25%, 35% or 50%
- Microprocessor controlled
- Alarm latching or auto reset
- Automatic gain control
- 12 VDC or 24 VDC operation
- Separate alarm and trouble contacts
- Remote Test Station

Beam Detector Spacing

On smooth ceilings, up to 60 ft. (18.288m) between reflective beams and not more than one half that spacing between a reflective beam and a sidewall. Other spacing may be used depending on ceiling height, airflow characteristics and response requirements. See NFPA 72 for further information.

Applications

- Open areas where ceiling heights exceed 25ft. (Warehouses, Hotel Atriums, Industrial Plants and School Gymnasiums)
- Public areas where cosmetics are of prime importance and detector heads need to be small and unobtrusive (Shopping Malls, Libraries, Theaters and Churches)

Benefits

- Reduces installation costs where 6 or more conventional detectors are required in a single area
- Reduces service time by taking advantage of optional remote test station located at ground level for system test without disruption of the site.



Dimensions

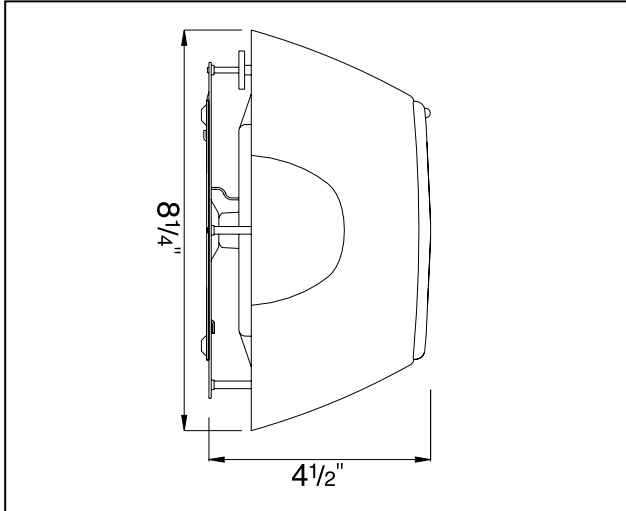

Operational Specifications

- Latching / Non Latching Alarm
- Fault condition (Trouble)
- 90% or more obscuration (Trouble)
- Automatic gain control
- Improper set up alignment (Trouble)
- Microprocessor Controlled
- 3 Sensitivity Selections
- Alarm Indicator—Red LED
- Trouble Indicator—Amber LED

Construction Specifications

Housing	Flame Retardent ABS
Rating	IP50
Finish	Grey/Black
Weight	Approx. 1.5 lbs (0.68 kg)
Dimensions	8.25"H x 4.5"D x 4.75"W (21.0cm H x 11.43cm D x 12.065cm W)

Electrical Specifications

Primary Input Power	10.2 to 30 VDC
Standby Current	4mA @ 24 VDC
Alarm Current	15mA @ 24 VDC
Relay Contacts	1A at 30VDC Resistive
Reset Time	5 seconds maximum
Start-up Time	10 seconds
Optical Wavelength	880nm.
Sensitivity	25%, 35%, 50%
Temperature Rating	-22°F to 131°F (-30°C to +55°C) For UL Listed Installations, 32°F to 100°F (0°C to 38°C).
Relative Humidity	10% to 93% RH non-condensing
Range	50RU 15-160 ft. (5m -50m) 100RU 160-330 ft. (50m - 100m)

Ordering Information

Model Number	Description
50RU	Reflective Beam Smoke Detector, 165 ft. (50m)
100RU	Reflective Beam Smoke Detector, 330 ft. (100m)
LLC	Remote Test Station
23901	Replacement Prism
0404	Data Link Assembly for LLC remote test station, 50RU/100RU
0209	Obscuration Test Filter
0608	Surface mount back box for 50RU/100RU beam detectors
0893	Surface mount wall bracket for 50RU/100RU beam detectors
9079	Surface mount bracket for Prisms, hole pattern for 1 or 4 prisms

